



A Platform for Systems Change: Engaging, Mapping, Aligning

Science is unanimous and increasingly aggressive in telling us that there is little time left for humanity to transform the economic system that is leading us to social and environmental crisis. Political movements and some economists advise that capitalism is no longer working for everybody. Across the world, governments struggle with issues that will endure beyond their tenure, protests flare, NGOs agitate more strongly, academics advocate change, global organisations demand urgent action, new businesses arise to serve the growing demand for answers in data, consultants embrace a wider agenda than growth and profitability. The news, social media, films, documentaries send messages of warning!

New technologies and paradigms emerge; zero-carbon, circular economy, rethinking capitalism, new economics, purposeful business, ESG accounting, localism, and many others...

Meanwhile natural disasters and the social implications become more real, more "lived" with every passing month.

Despite the signs, the messages, even the realisation, response has not been revolutionary, not evolutionary, not anything close to what is required. Governments (big governments) remain in denial or fear or both, business does not lead or exercise the power it clearly has, consumers still prioritize convenience, speed and price point. Amongst pockets of good intention, the mainstream sits tight, delaying plans to address global crises, hoping someone else will solve the problems of the planet, frozen in the headlights of complexity, rather than seeing themselves as fundamental drivers of change. Meanwhile, the dominant operating models and reinforcing dynamics of our society and economy thrive... pushing the planet beyond its natural resource boundaries, threatening our way of life, standards of living, and the biosphere itself - if not for ourselves then certainly for the immediate generations following.

To address this paradox, nearly every recent advocate for change talks about the need for joined-up systemic change. Still, stakeholders often come at the problems with their own perspectives and interests, and even when more systemic in their outlook, tend to have a dogged belief in the primacy of their own viewpoint. This results in a proliferation of new models, approaches, data sets, and proposals for change; an over-abundance of well-meaning initiatives that creates a noisy confusion of activity and a lack of aligned understanding and concerted action. And this confusion exacerbates the real issue: we're grappling with a problem of collective action. Stakeholders are locked into the current mode of operation, constrained internally by their own thinking and interests, and externally by the system in which they operate. To break this impasse will require a fundamentally different approach to generating agreement on how to move forward together.

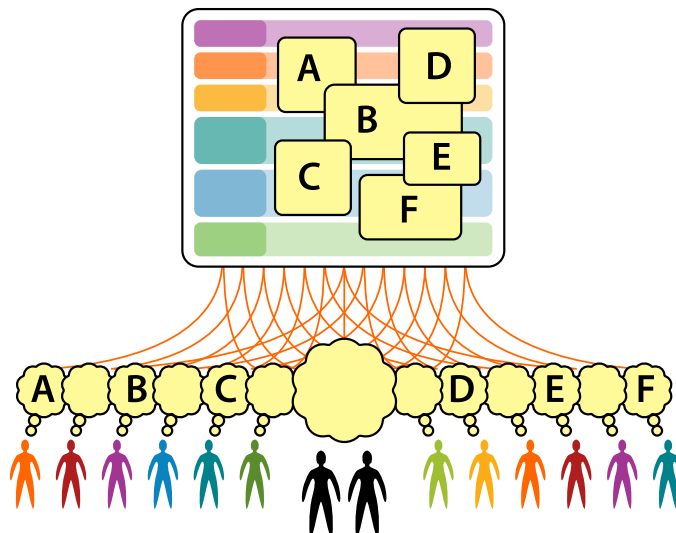

Forging a shared view of each other's perspectives and interests is essential for collaborative systems change.

The first step to coordinated action requires multi-stakeholder engagement to forge a shared view of shared problems. Taking the time for meaningful discussion and insight, rather than allowing time to pass in confused advocacy. Building understanding, trust, ownership, and an orientation to change grounded in an appreciation of the implications for others in the system. Many commentaries already advocate for a platform for informed decision and coordinated action. However, the recognition of the *need* for systems change has been running far ahead of our ability to actually *do* systems change.

Nexial believes that the lack of an effective platform for shared systemic understanding and informed discussion is a critical gap that is slowing the momentum for change. To fill this gap, we are committed to building coalitions of stakeholders (from business, government, community, NGOs, financial institutions, media, etc), who are already in the arena and trying to make change happen and working with them to map the system. Charting the current reality, designing a future system, devising a transition plan, all in a format where everyone can see themselves, their interactions and interdependencies, their links to potential leverage points, and the implications of disruptive trends. Such a mapping tool can then be extended to include a much wider community of stakeholders to generate ideas, debate, collaborate, and take ownership of an aligned and dramatically faster change model.

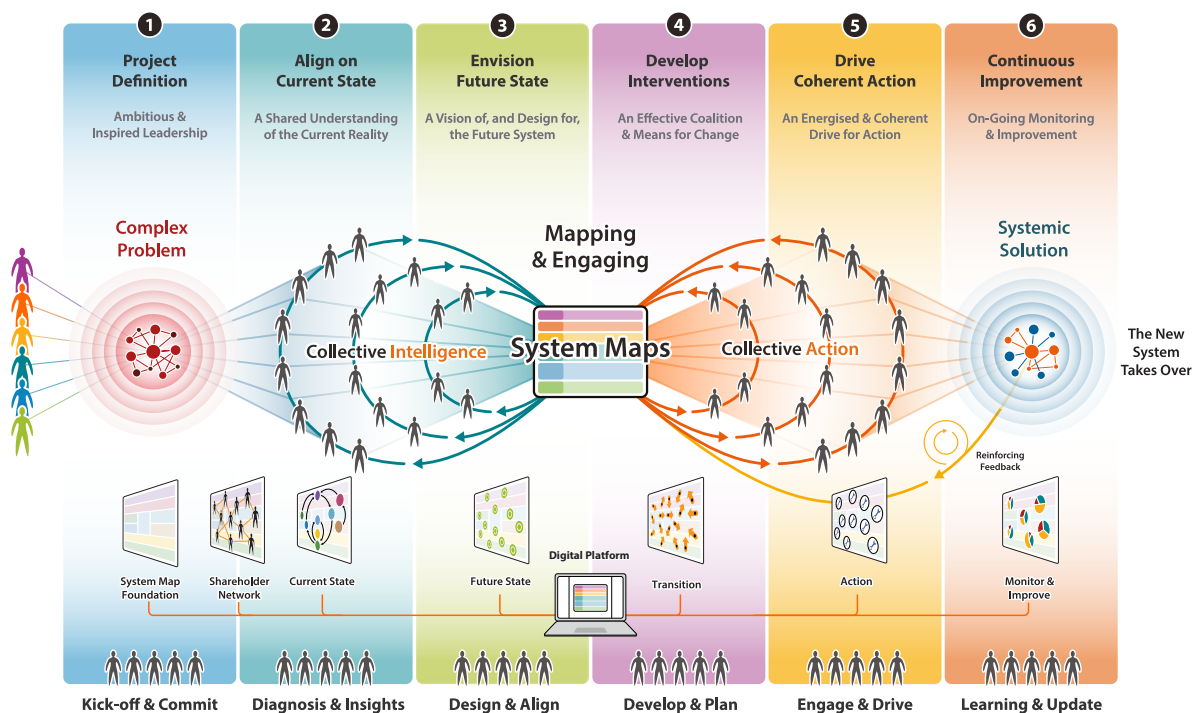

The Nexial digital platform enables a well-structured change process; engaging stakeholders in developing a strategic change agenda that will drive coherent action.

Through 25 years of facilitating systemic-change we bring stakeholder perspectives to bear on multi-faceted issues and help them to gain a more holistic view of the systems they work in. We have seen how innovation on the edges tends to stay on the edges and will remain slow and incremental until we address the large-scale structural problems head-on.

We are committed to bringing this experience to bear on the big global problems we face, to contributing what we can to drive the step change we need, while it's still not too late.